

Blade Grip Assembly.

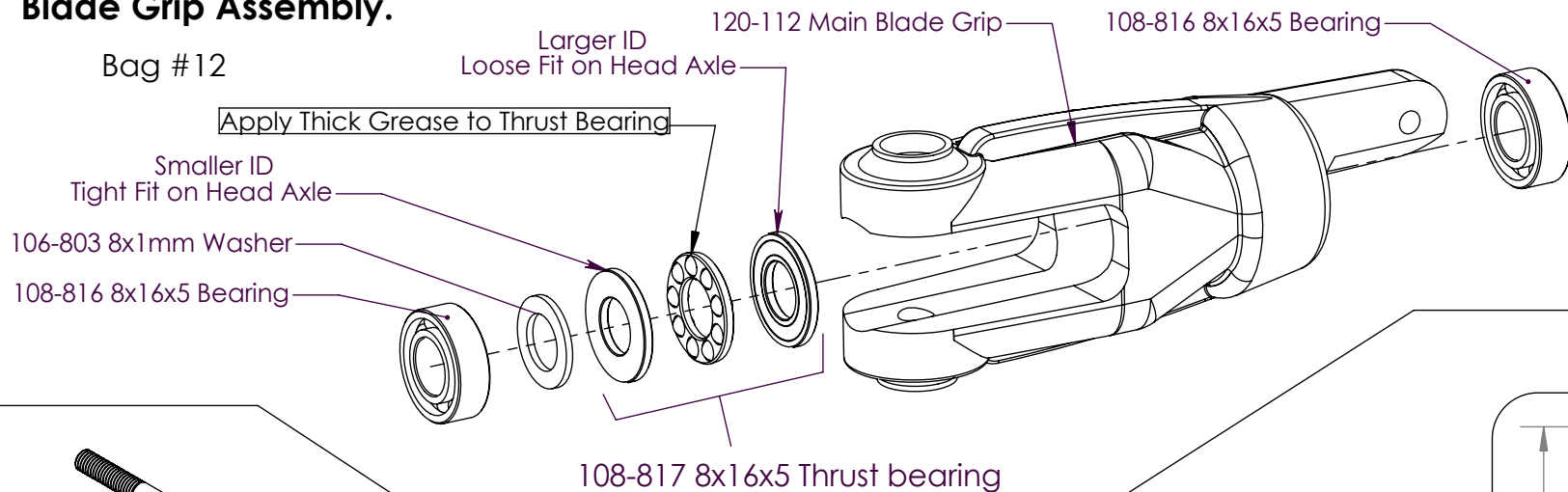

Rotor Head Assembly

Bag #12

Dampening Options

Add amount to Both sides Each Side of Head
 Loose = 1 Thick
 Normal = 1Thick, 1 Thin
 Tight = 1 Thick, 1 Medium

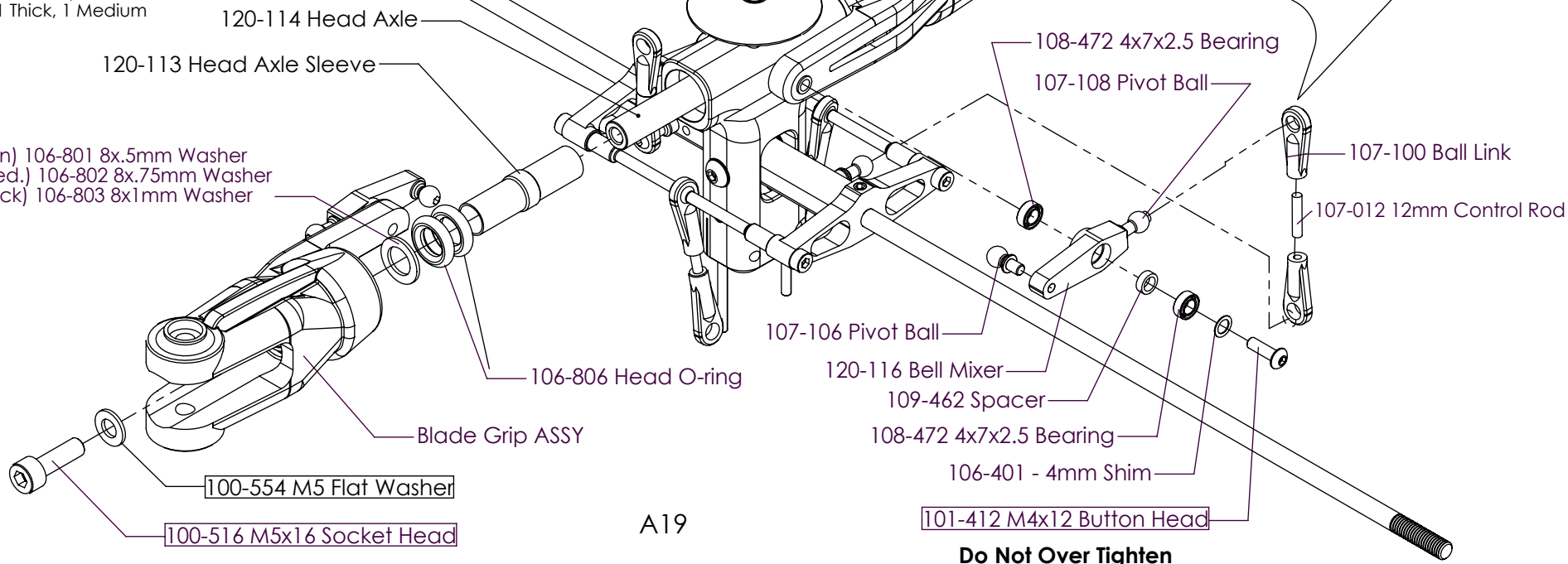

Do Not Over Tighten